

Bauplan für klappbare Werkbank

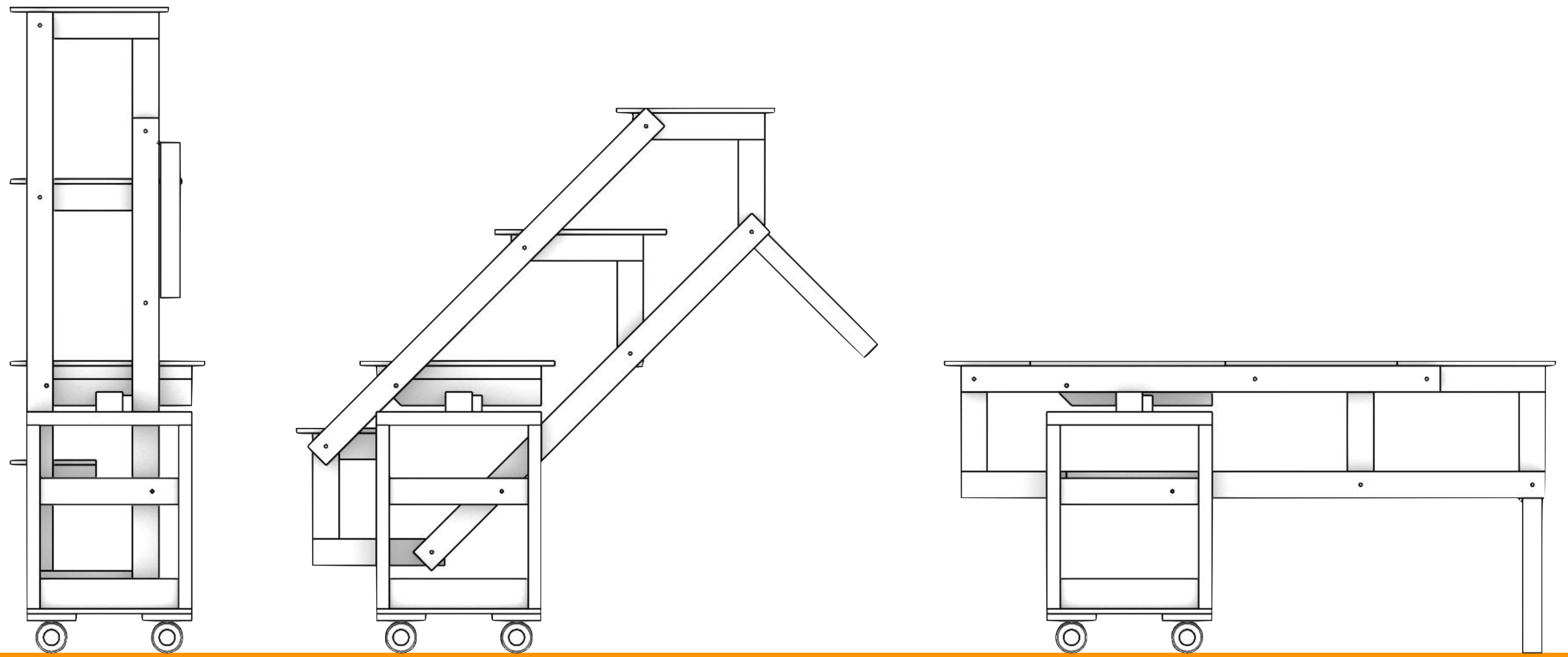

Bauplan für klappbare Werkbank

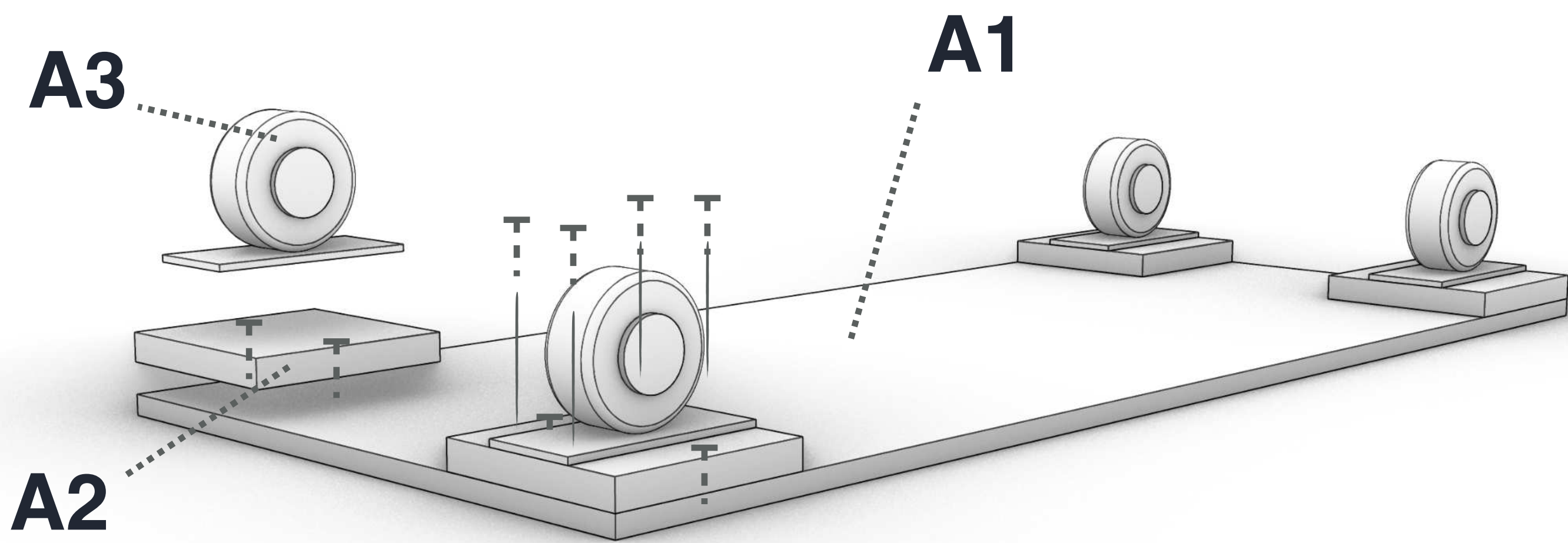

Schrauben
Senkkopfschrauben 4,0 x 35
4 Stück



Schrauben
Senkkopfschrauben 4,0 x 35
16 Stück

Material

A1	Grundplatte	Multiplex 15mm - 1130 x 500	1x
A2	Verstärkung	Multiplex 21mm - 150 x 150	4x
A3	Schwerlastrollen (2x mit Bremse)	100 mm	4x

Werkzeug

W1	Bleistift, Winkel, Linal, Maßband, Gliedermaßstab	<input type="checkbox"/>
W2	Akkuschrauber, Holzbohrer-Set, Bit-Set	<input type="checkbox"/>
W3	Kappsäge	<input type="checkbox"/>
W4	Kreis/ Tauchsäge mit Schiene	<input type="checkbox"/>
W5	Holzbohrer ø10 & Forstner Bohrer ø20 - ø25	<input type="checkbox"/>

Zubehör

Z1	Senkkopfschrauben 4,0 x 35	36x
Z2	Senkkopfschrauben 5,0 x 90	32x
Z3	Senkkopfschrauben 4,0 x 70	8x
Z3	Senkkopfschrauben 6,0 x 120	22x

Bauplan für klappbare Werkbank

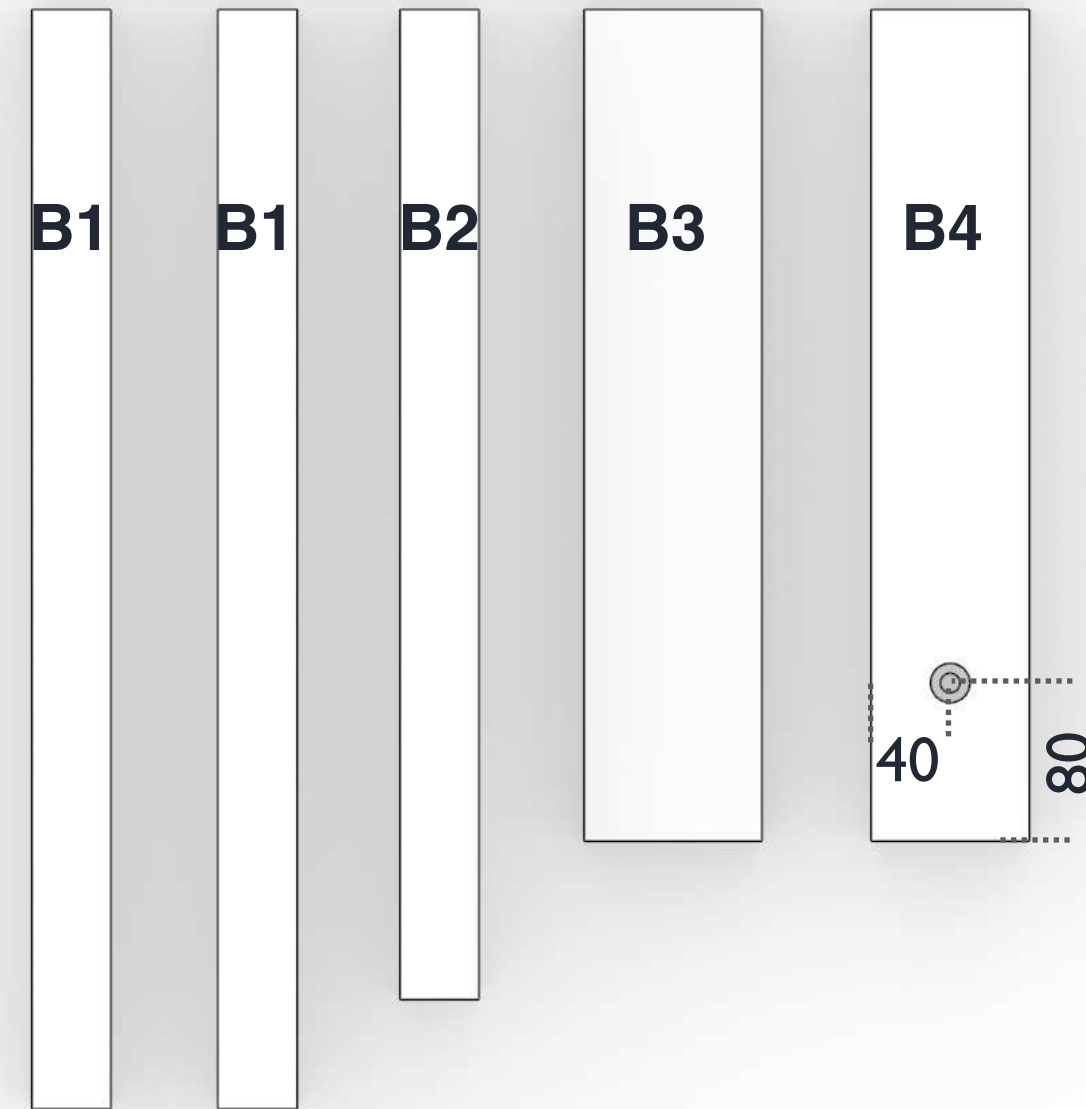

Bohren
 Holzbohrer $\varnothing 10,0$
 Forstner Bohrer $\varnothing 20-25$
 ! EINSEITIG

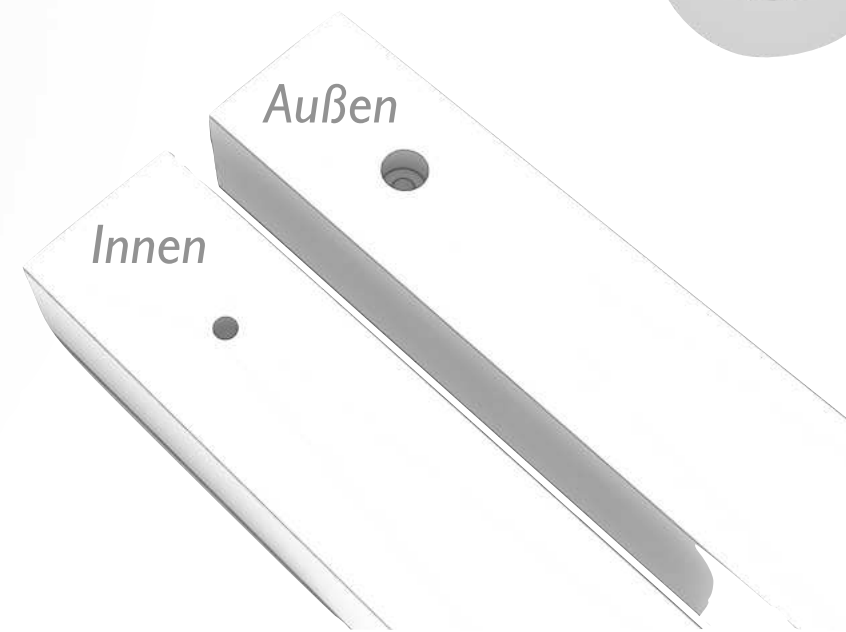
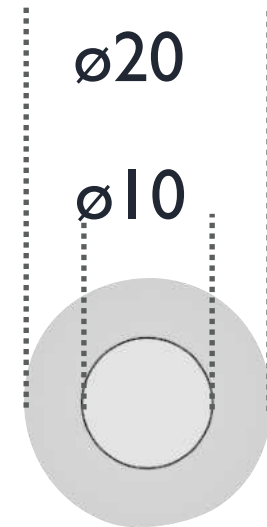

Material

B1	Strebe Aufrecht	Vollholz - 555 x 90 x 40	4x
B2	Strebe Oben	Vollholz - 500 x 90 x 40	2x
B3	Strebe Unten	Vollholz - 420 x 90 x 40	2x
B4	Strebe Mitte	Vollholz - 420 x 80 x 60	2x

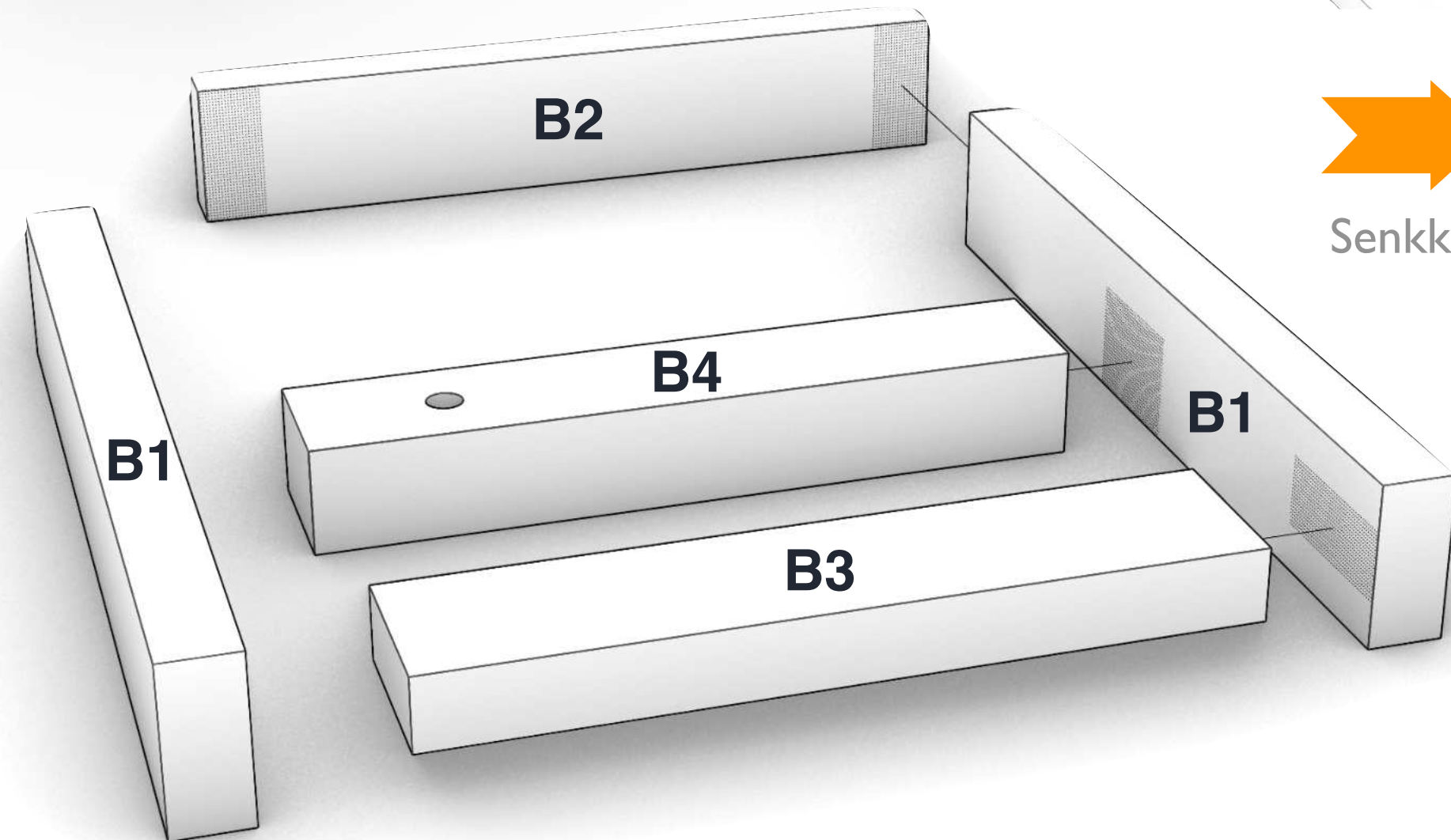

Schrauben
 Senkkopfschrauben 5,0 x 90
 24 Stück

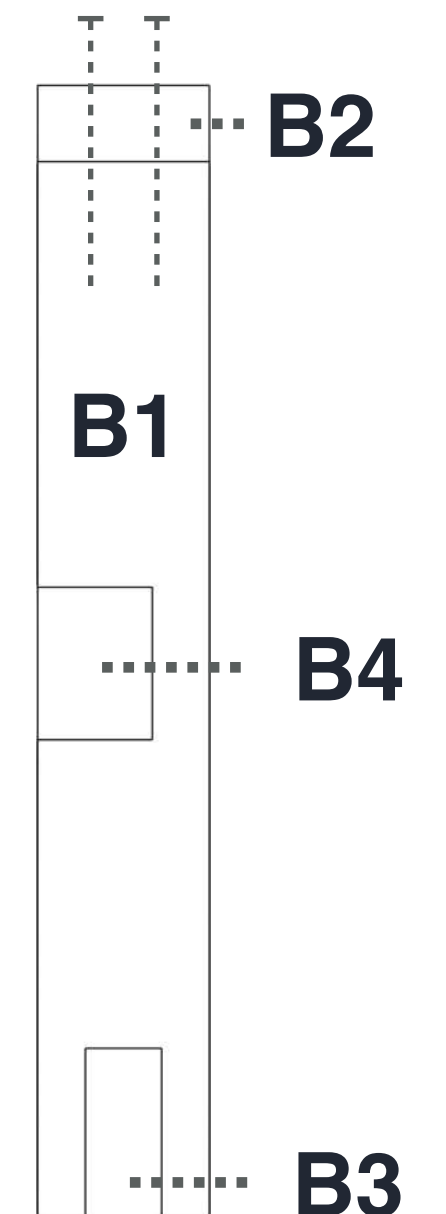
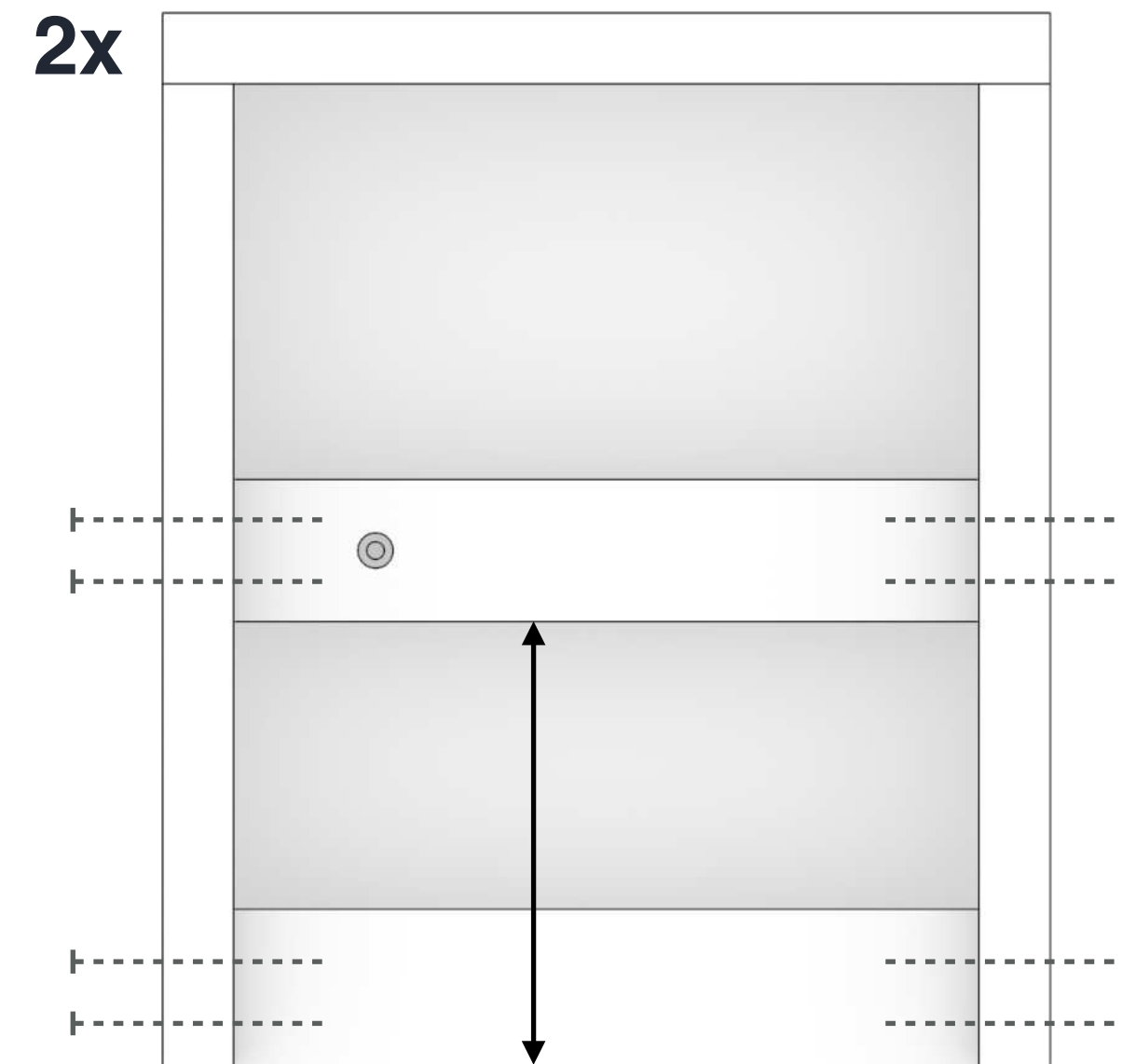

Bauplan für klappbare Werkbank

Material			
C1	Querstrebe	Vollholz - 1130 x 80 x 60	1x
C2	Anschlagstück	Vollholz - 155 x 60 x 35	2x

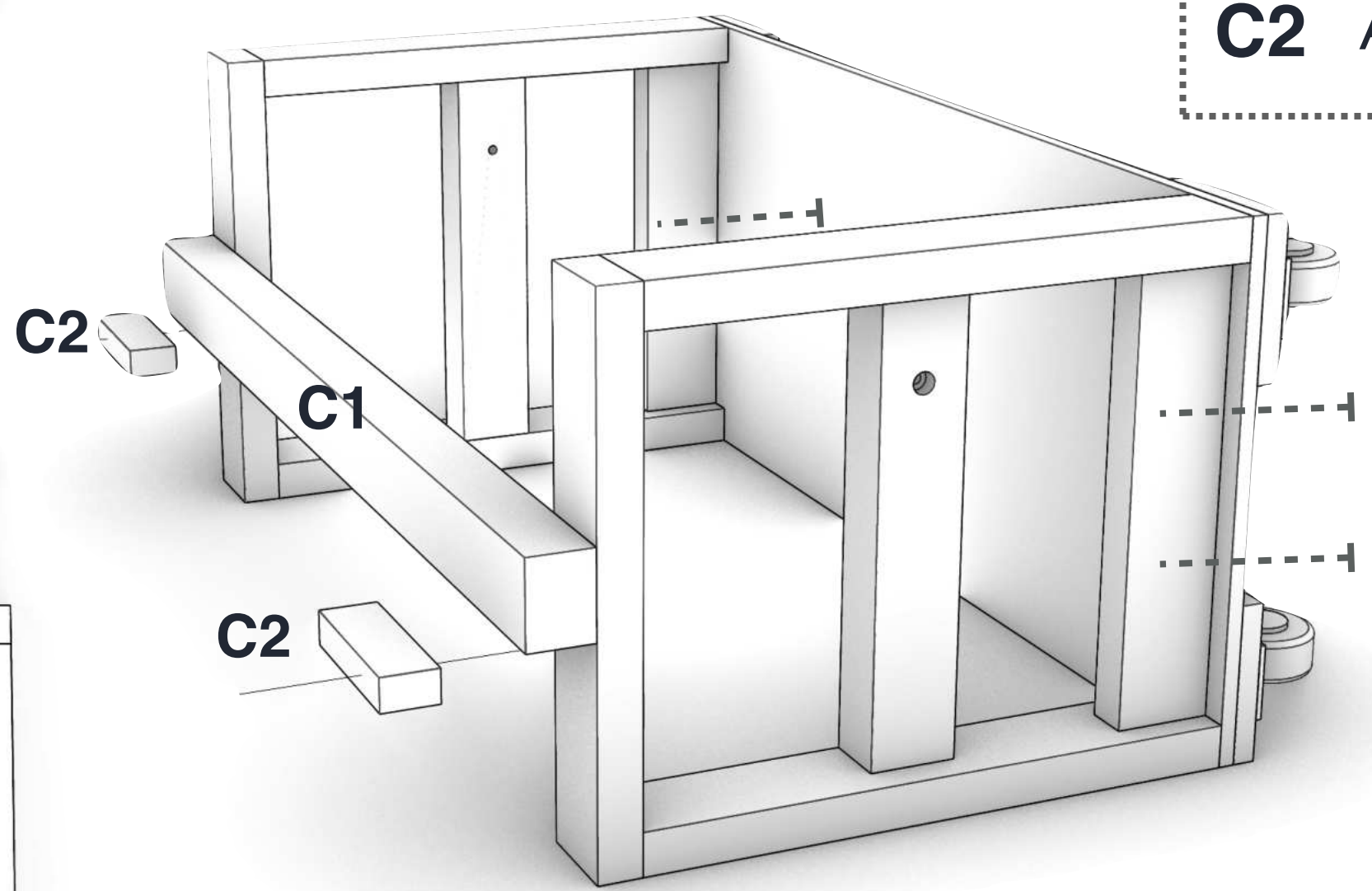
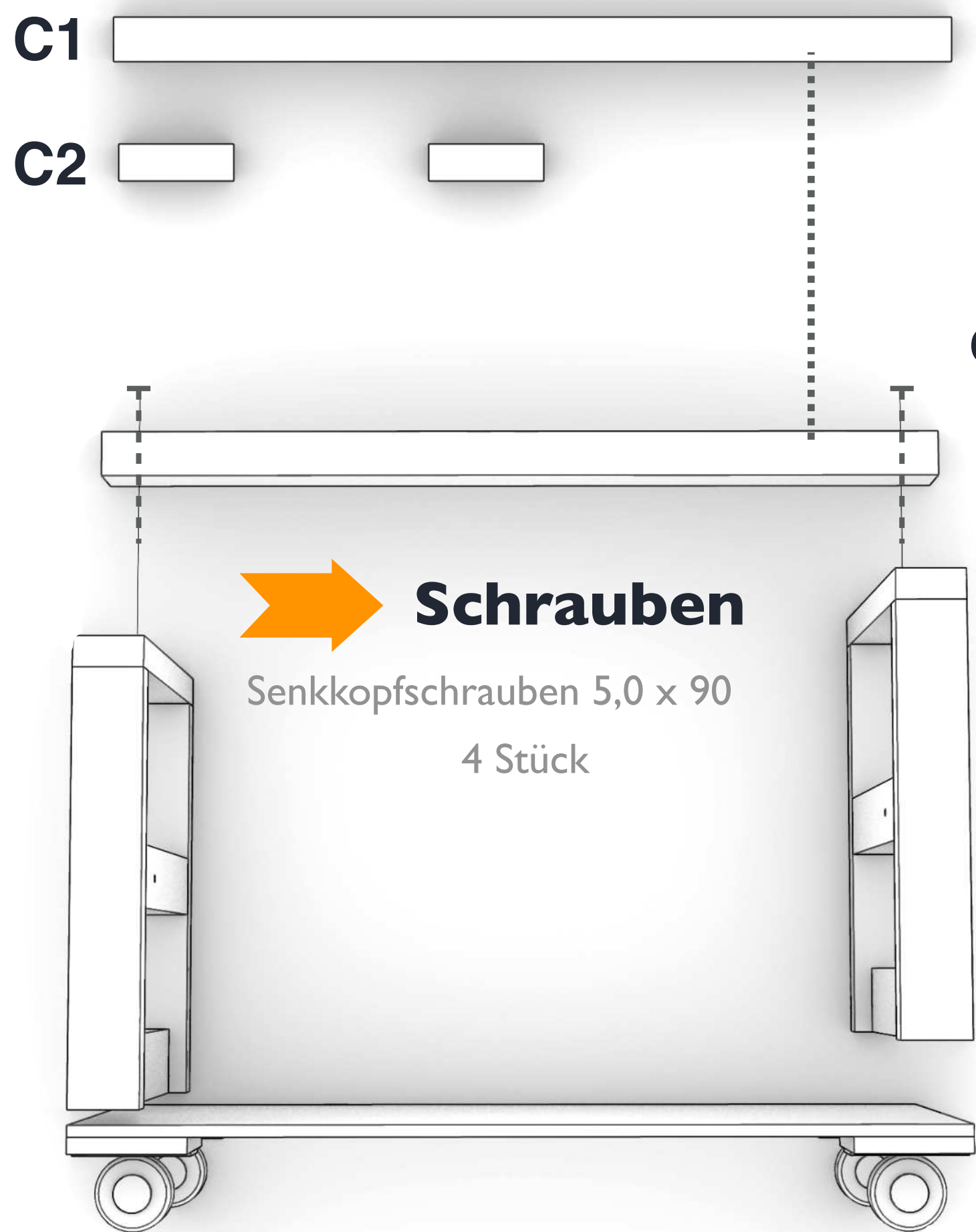

Ansicht nicht maßstabsgetreu

Bauplan für klappbare Werkbank

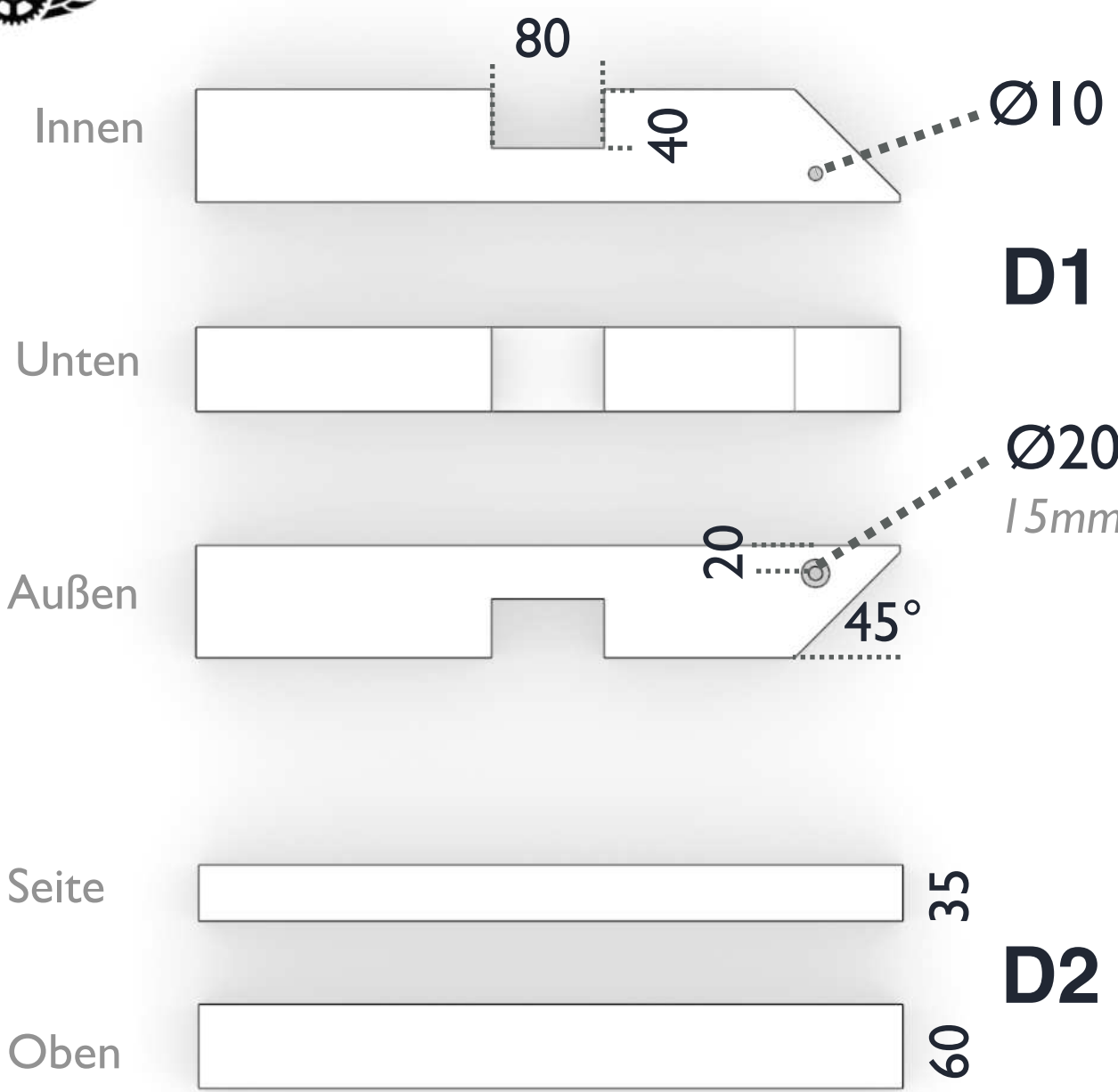

Schrauben

Senkkopfschrauben 4,0 x 70
4 Stück

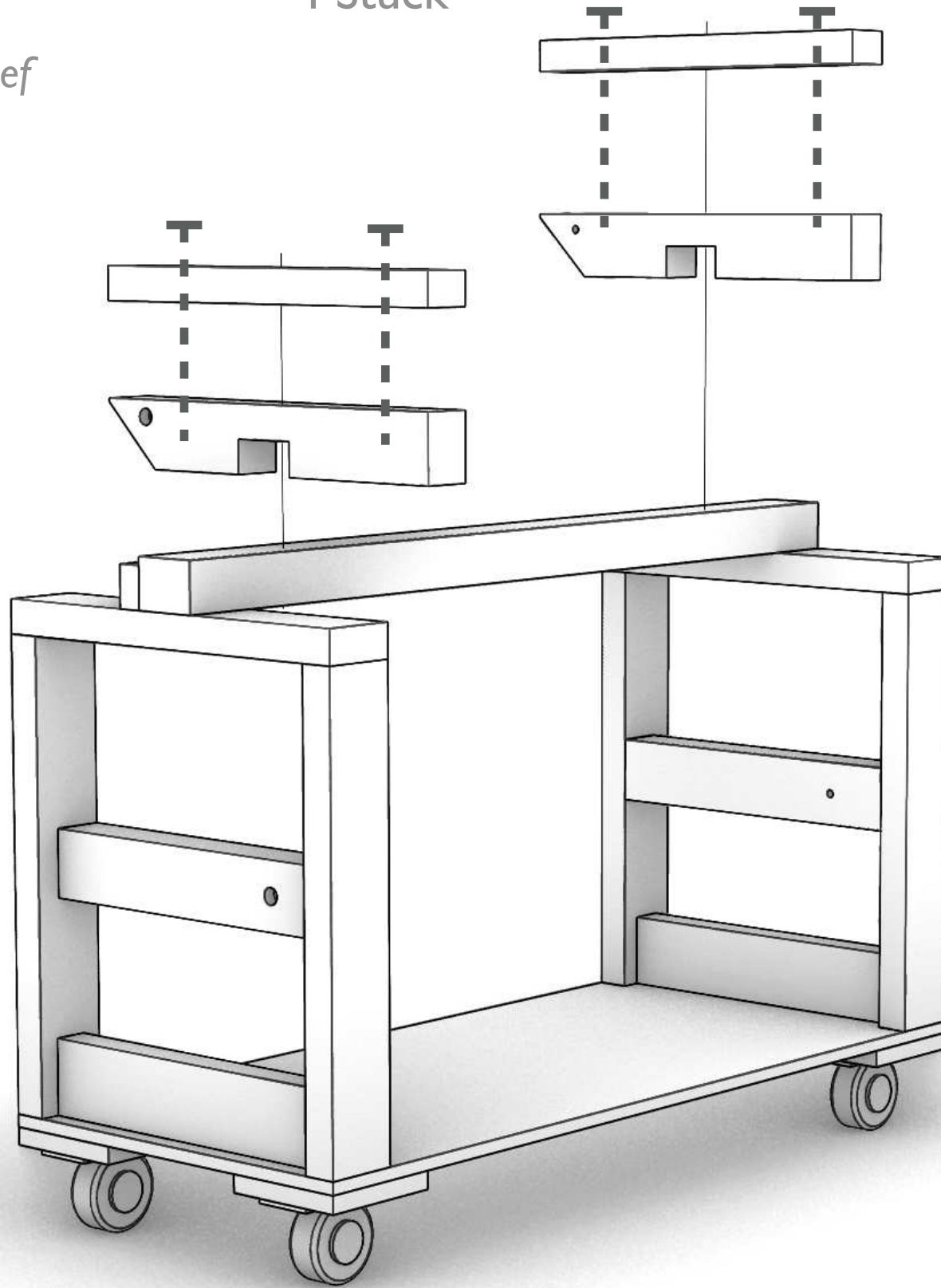

Schrauben

Senkkopfschrauben 4,0 x 35
4 Stück

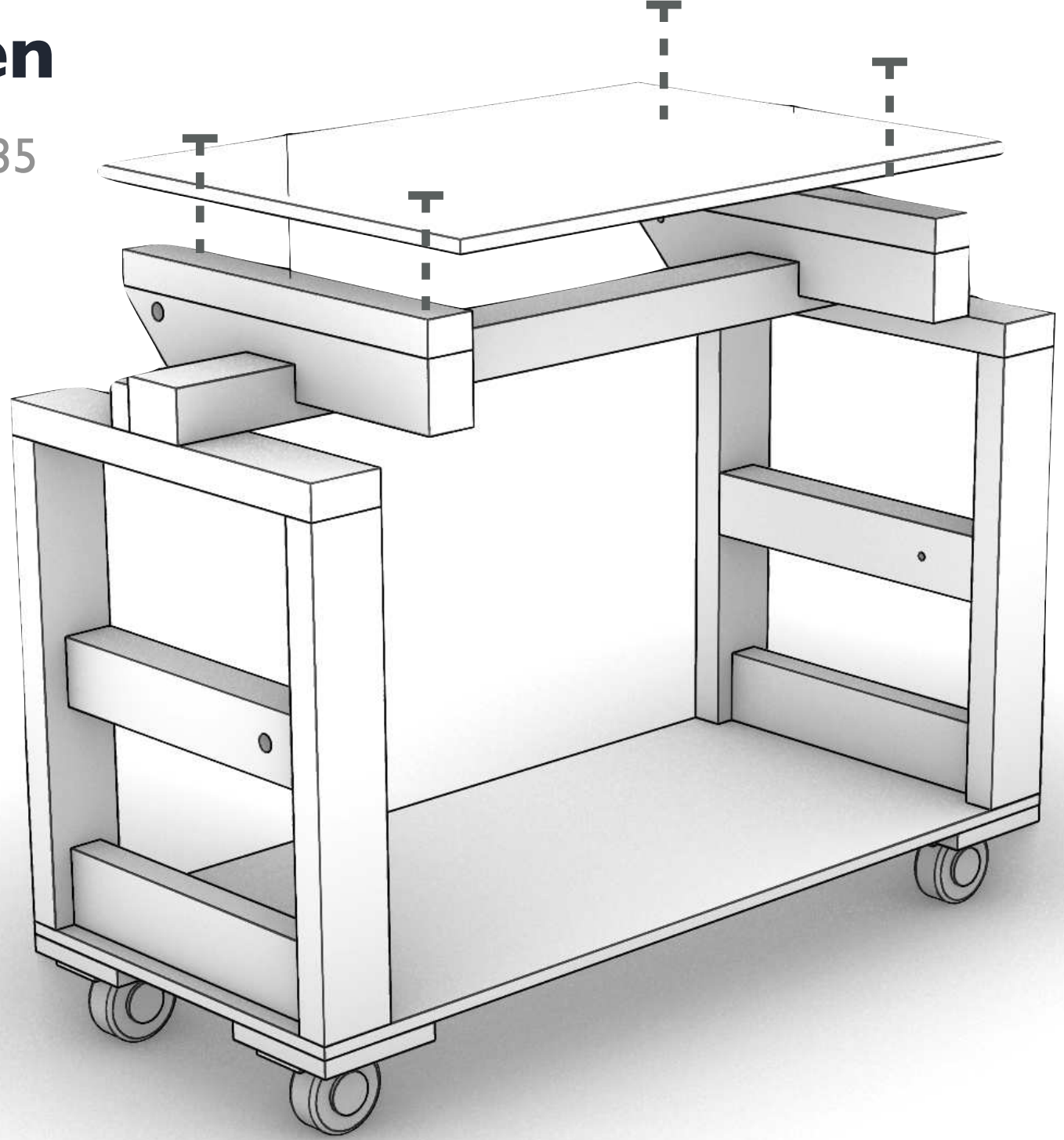

Material

D1	Trägerelement	Vollholz - 500 x 80 x 60	2x
D2	Aufdopplung	Vollholz - 500 x 60 x 35	2x
D3	Arbeitsplatte	Multiplex 15mm - 820 x 590	1x

Bauplan für klappbare Werkbank



Material

E1	Klappschenkel Oben	Vollholz - 1450 x 80 x 60	2x
E2	Klappschenkel Unten	Vollholz - 1450 x 80 x 60	2x

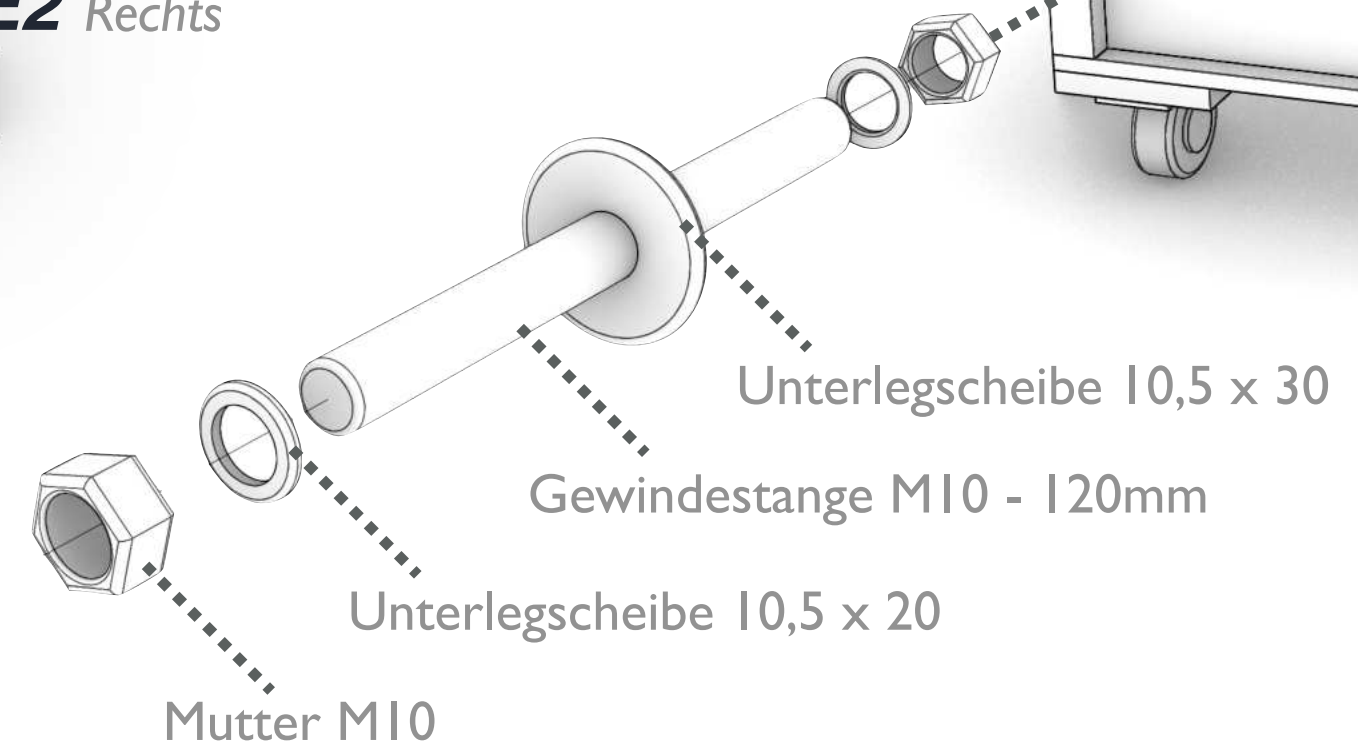
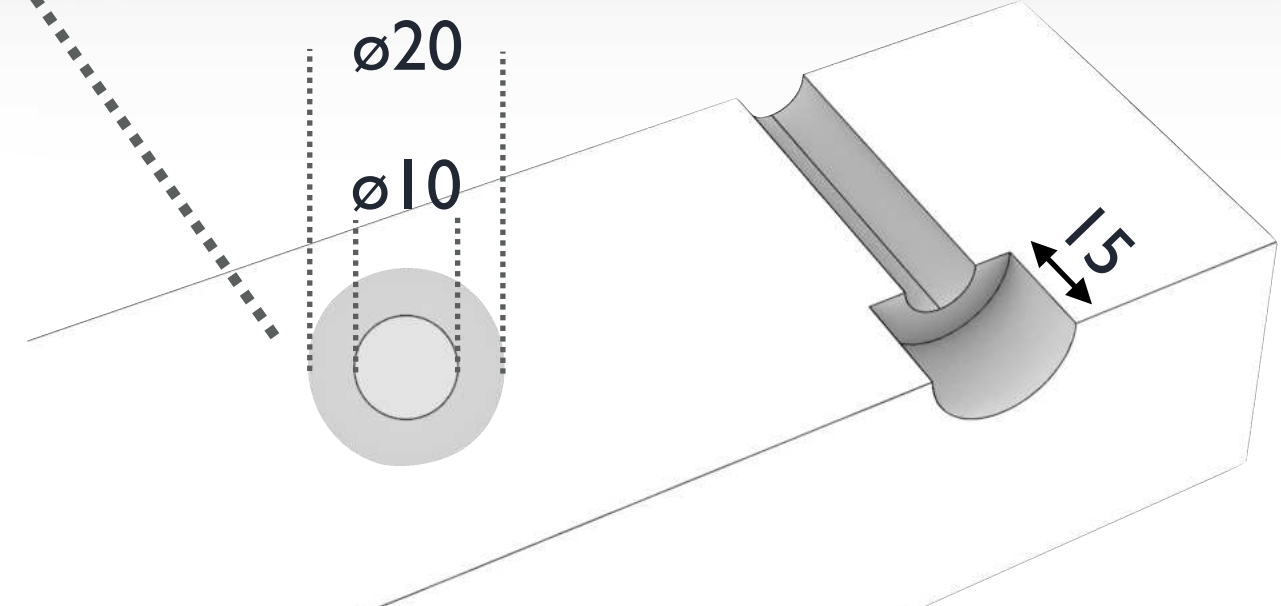
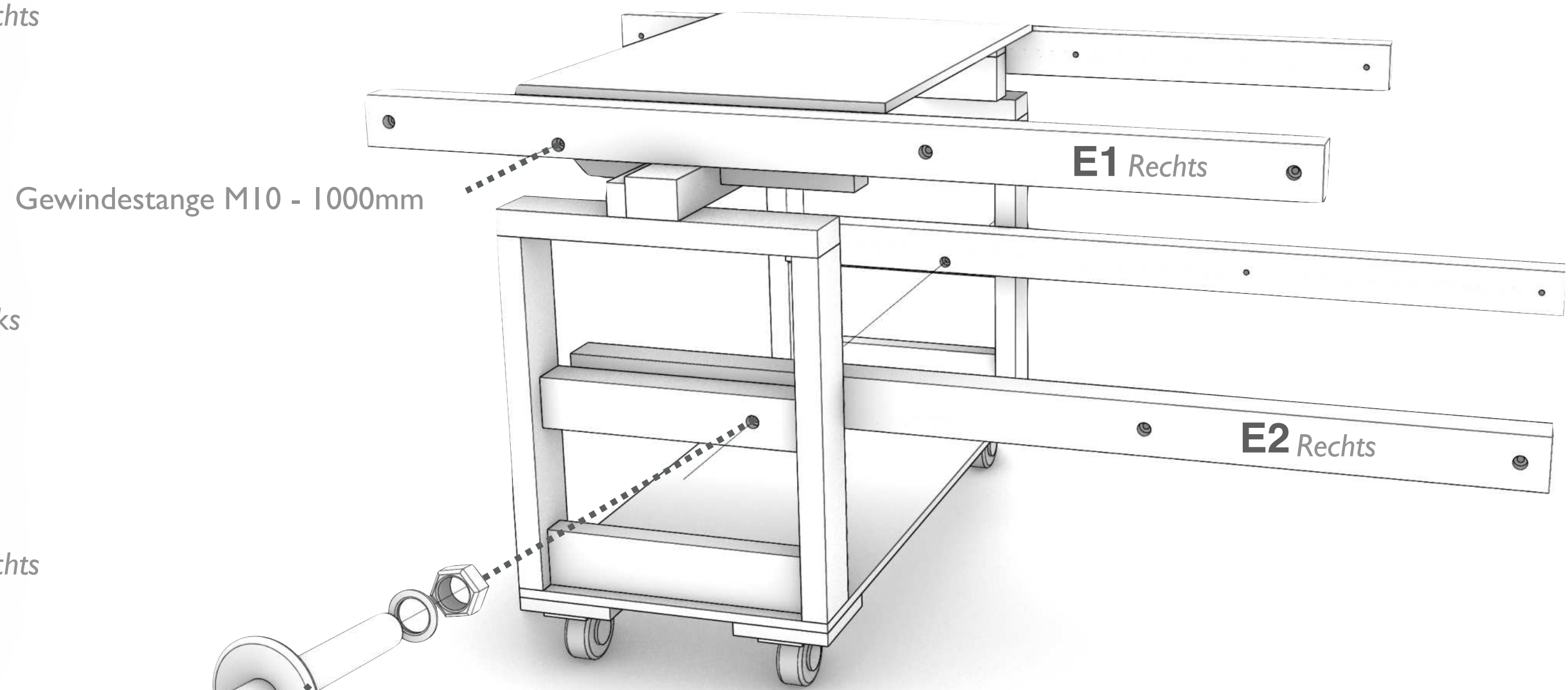

Ansicht nicht maßstabsgetreu

Bauplan für klappbare Werkbank

Links

Rechts

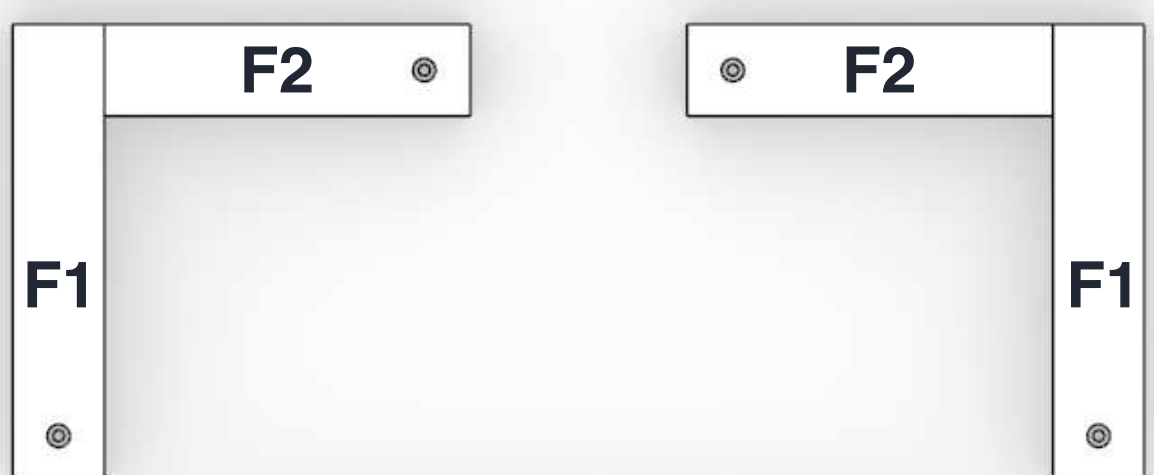
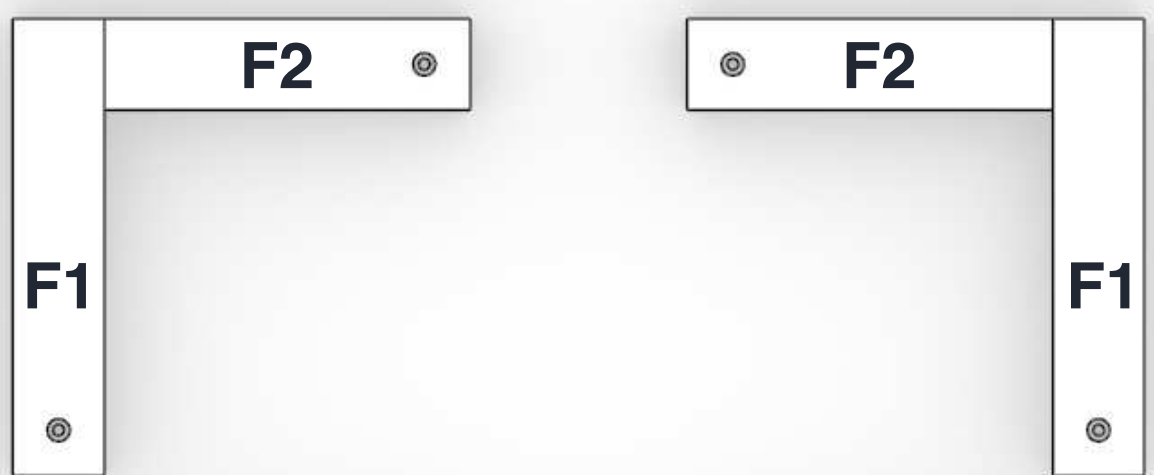
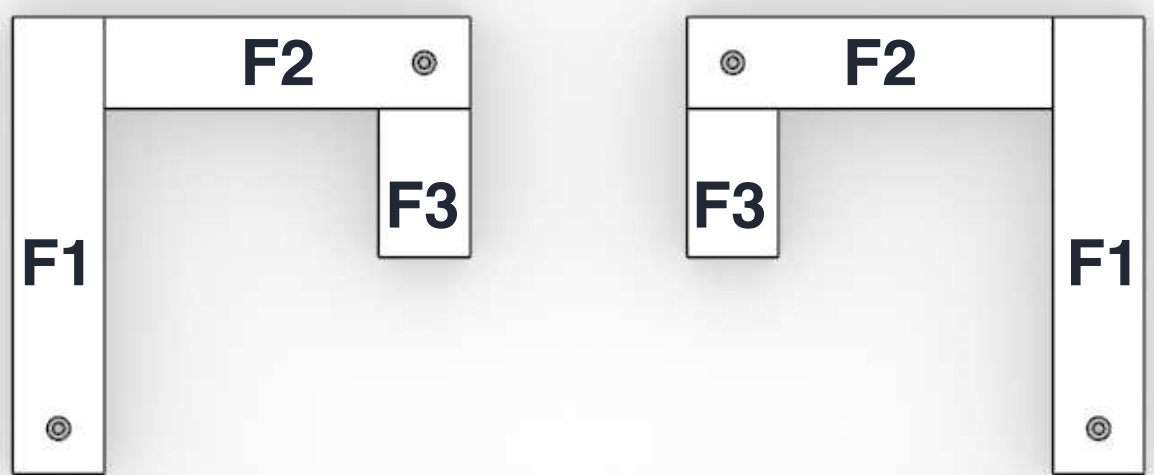

F4

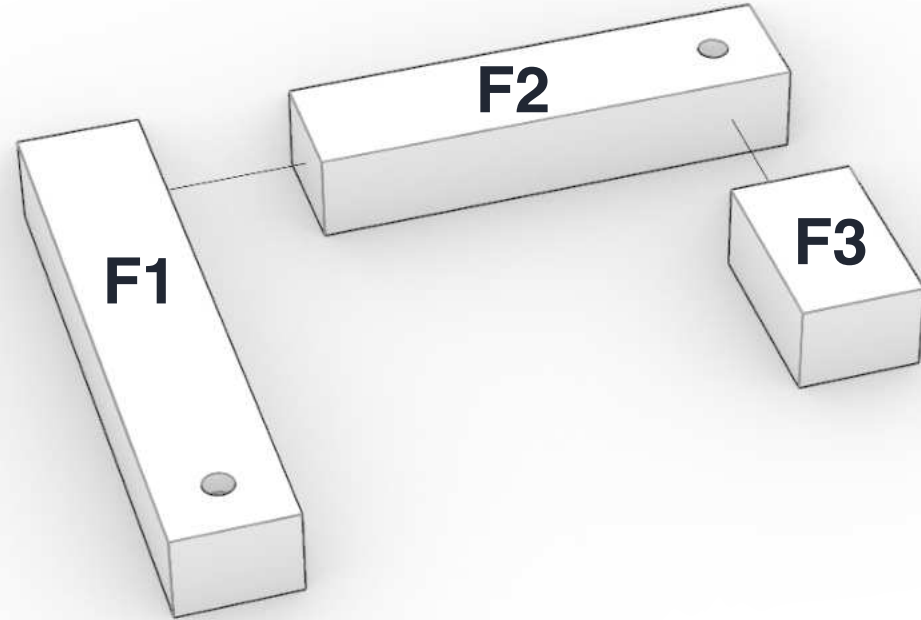
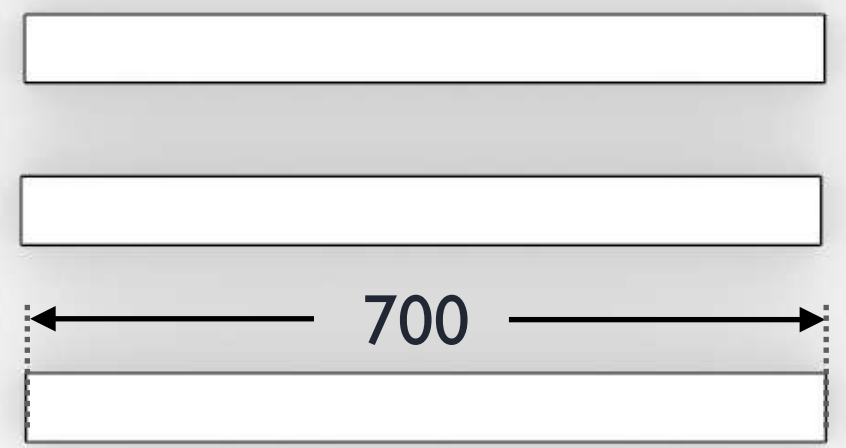

Material

F1	Schenkel lang	Vollholz - 80 x 60 x 400	6x
F2	Schenkel kurz	Vollholz - 80 x 60 x 320	6x
F3	Ansatzstück	Vollholz - 80 x 60 x 130	2x
F4	Querstrebe	Vollholz - 80 x 60 x 700	3x

Schrauben

Senkkopfschrauben 6,0 x 120

16 Stück

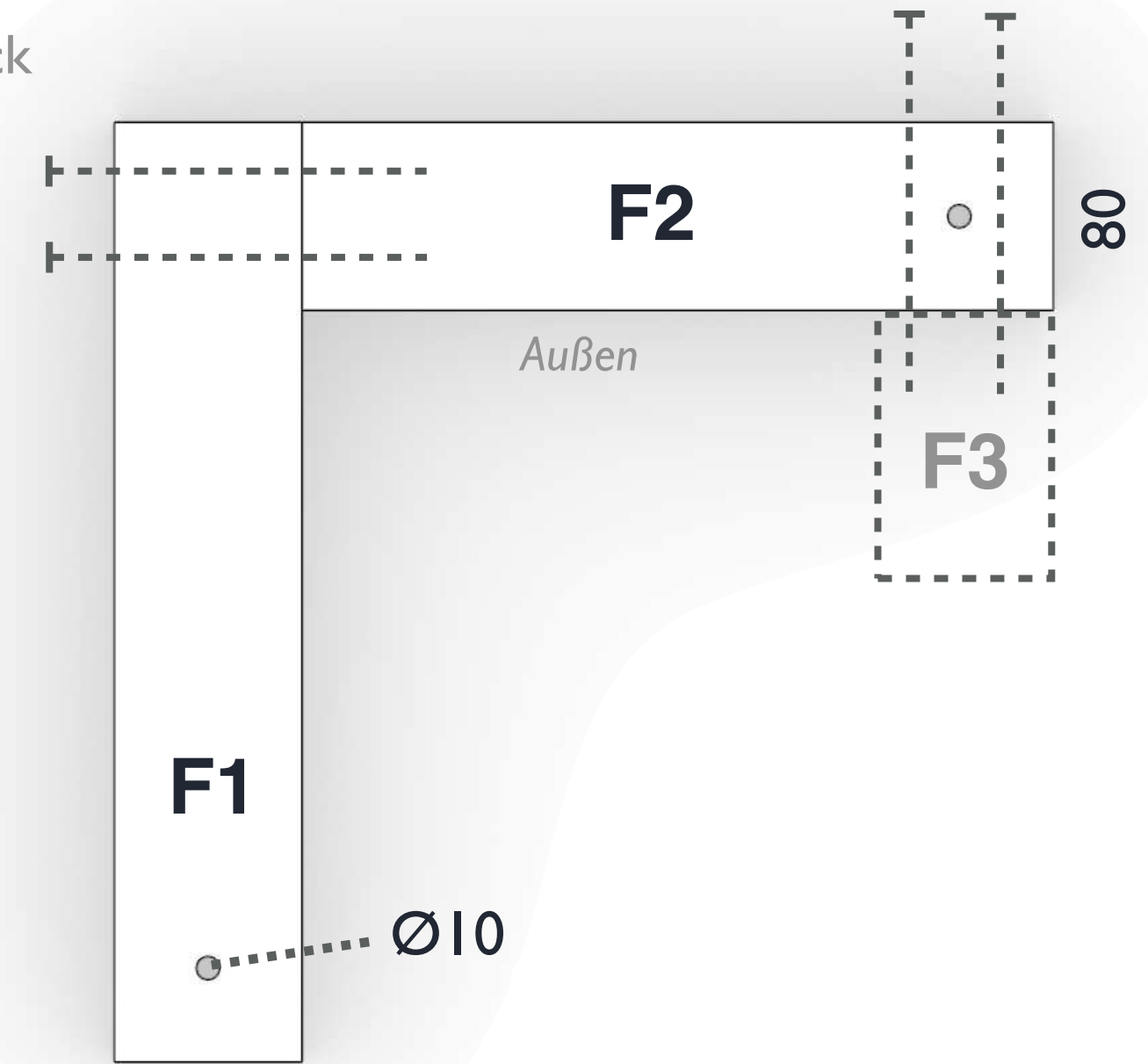
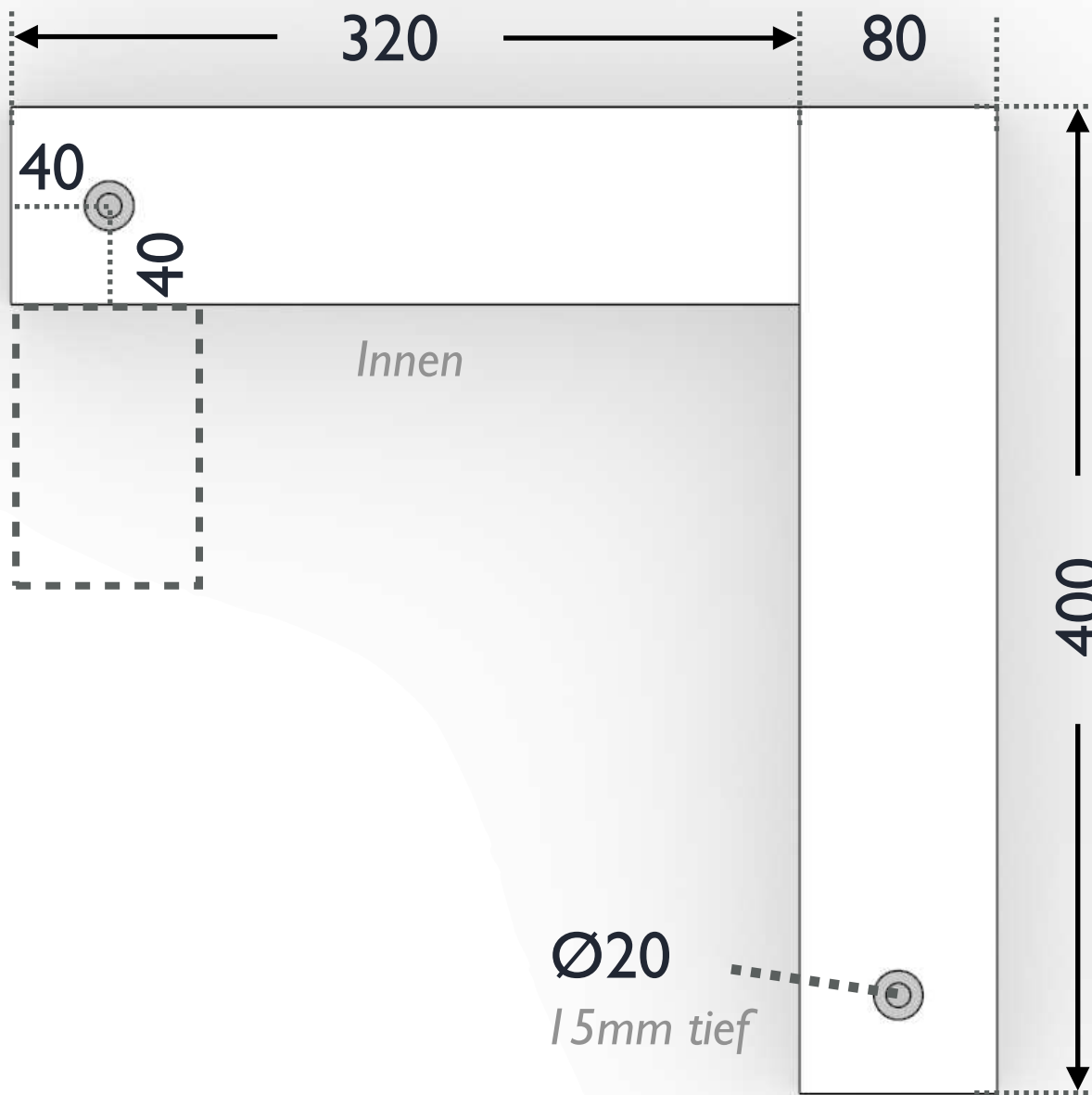

Ansicht nicht maßstabsgetreu

Bauplan für klappbare Werkbank

F2

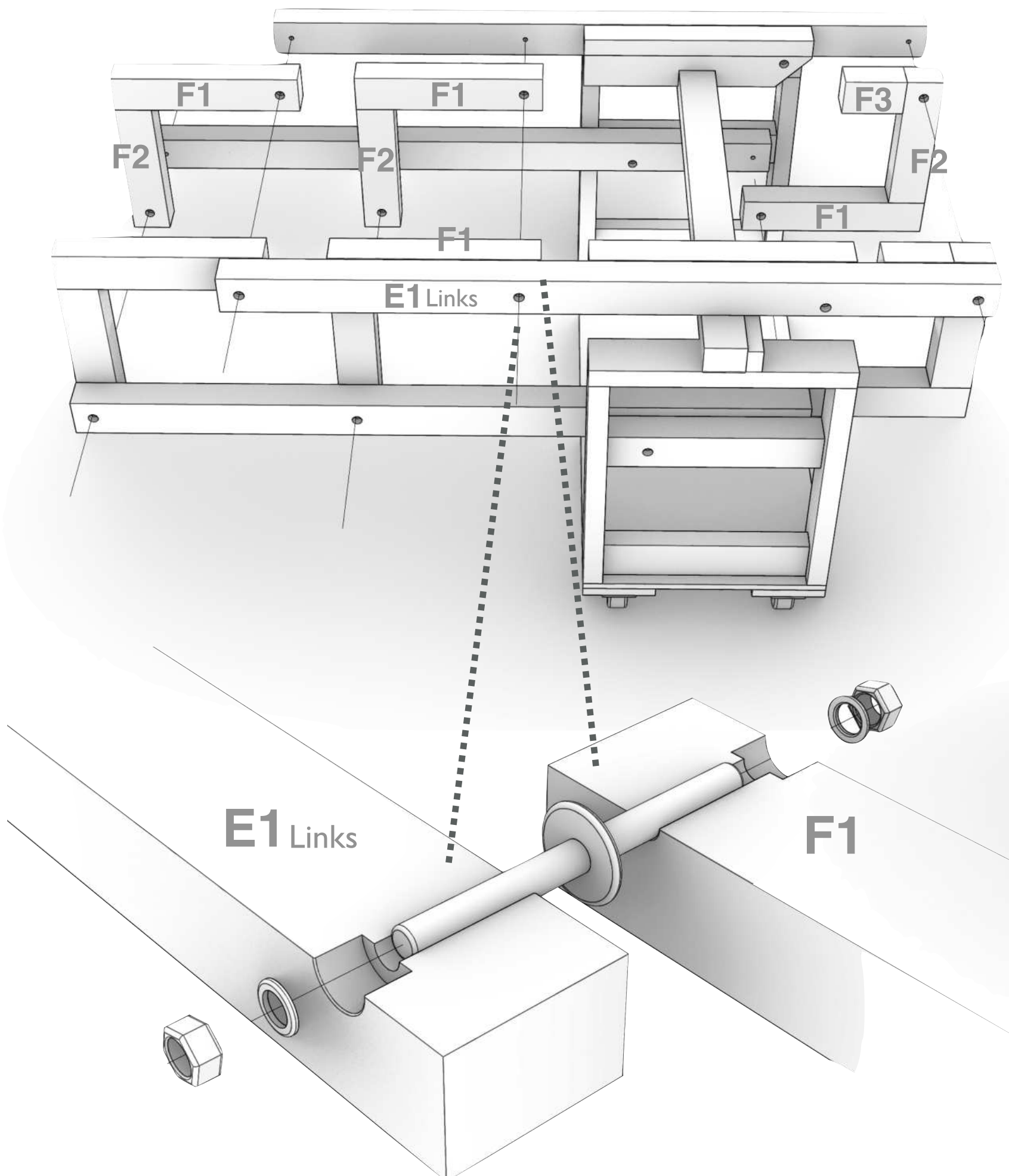

Schrauben
Gewindestange M10 120mm

Schrauben
Senkkopfschrauben 6,0 x 120
6 Stück

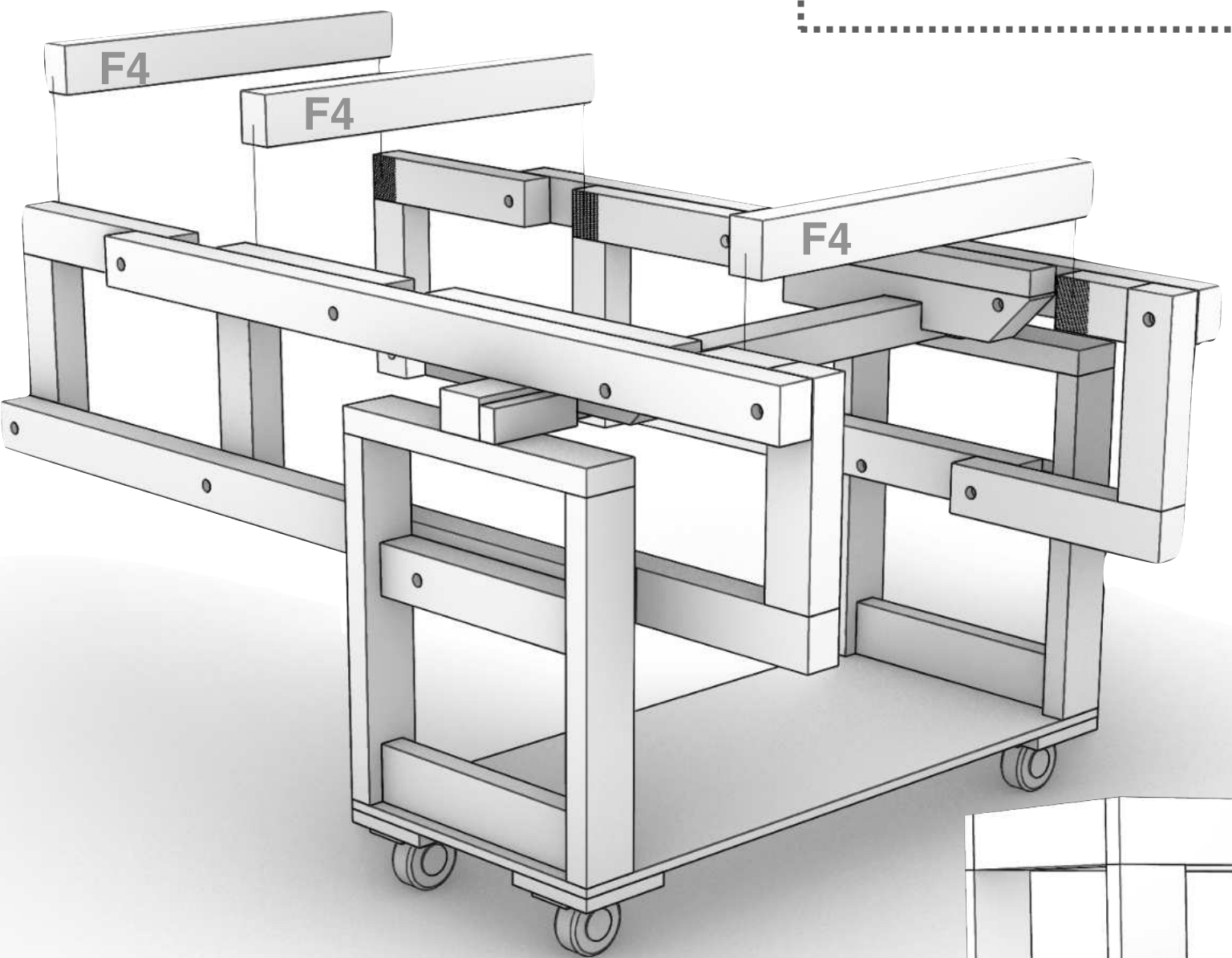

Schrauben
Senkkopfschrauben 4,0 x 35
12 Stück

Material

F4	Querstrebe	Vollholz - 80 x 60 x 700	3x
F5	Beine	Vollholz - 80 x 60 x 500 (472)	2x

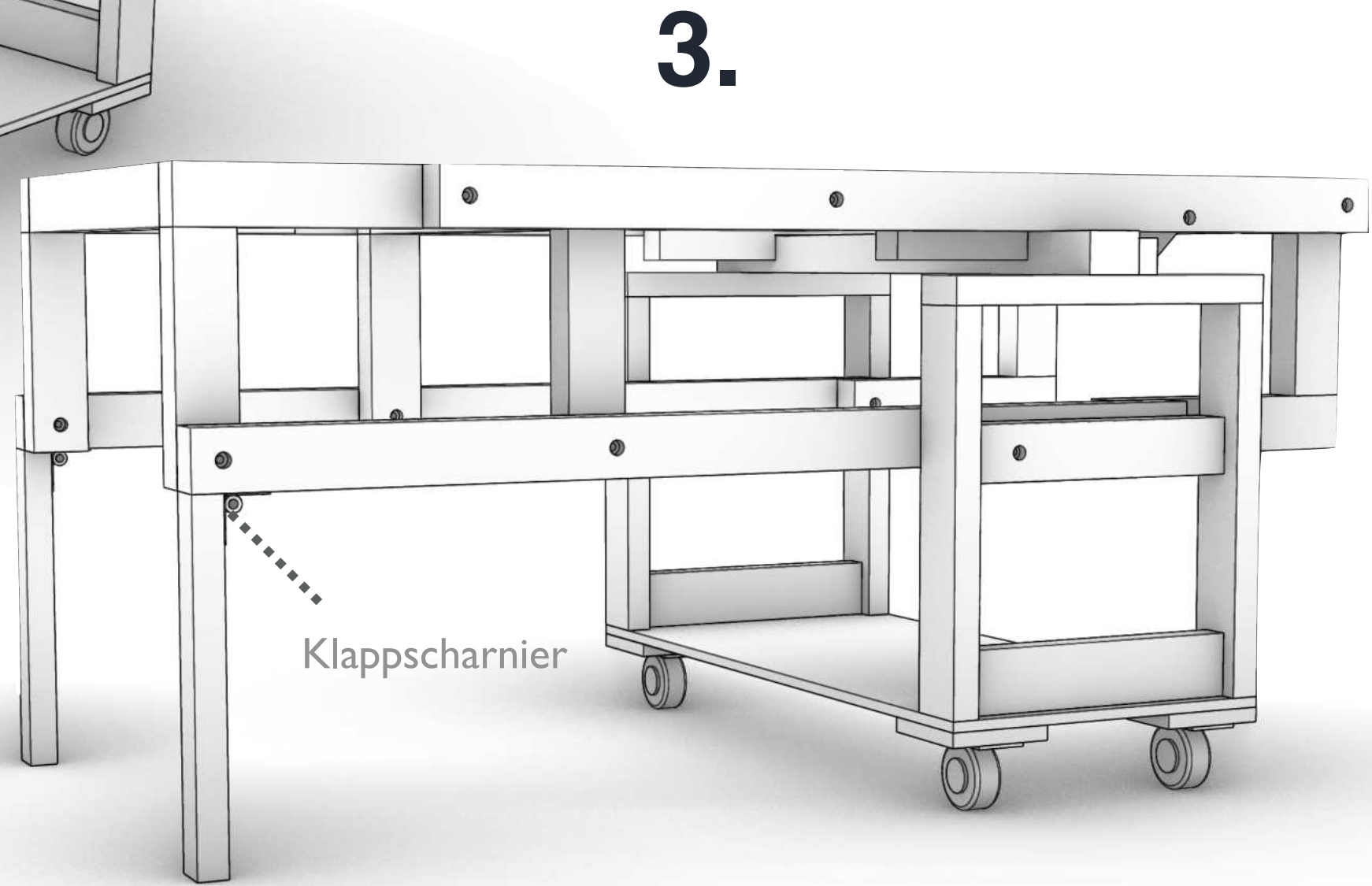

Bauplan für klappbare Werkbank

Schrauben

Senkkopfschrauben 4,0 x 35

16 Stück

ca. 1mm

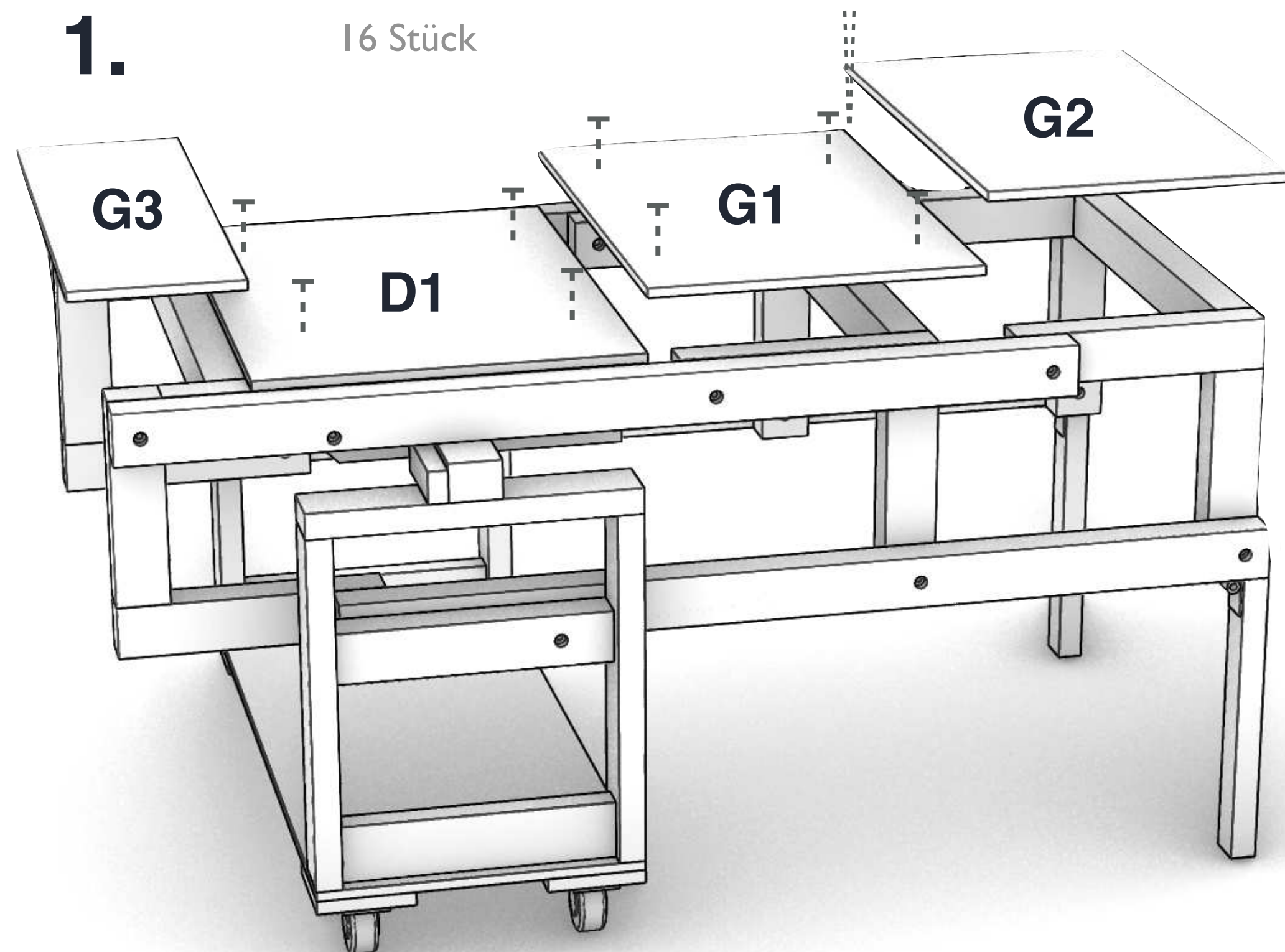

Material

D1	Arbeitsplatte	Multiplex 15mm - 820 x 590	1x
G1	Arbeitsplatte	Multiplex 15mm - 820 x 520	1x
G2	Arbeitsplatte	Multiplex 15mm - 820 x 480	1x
G3	Arbeitsplatte	Multiplex 15mm - 820 x 260	1x

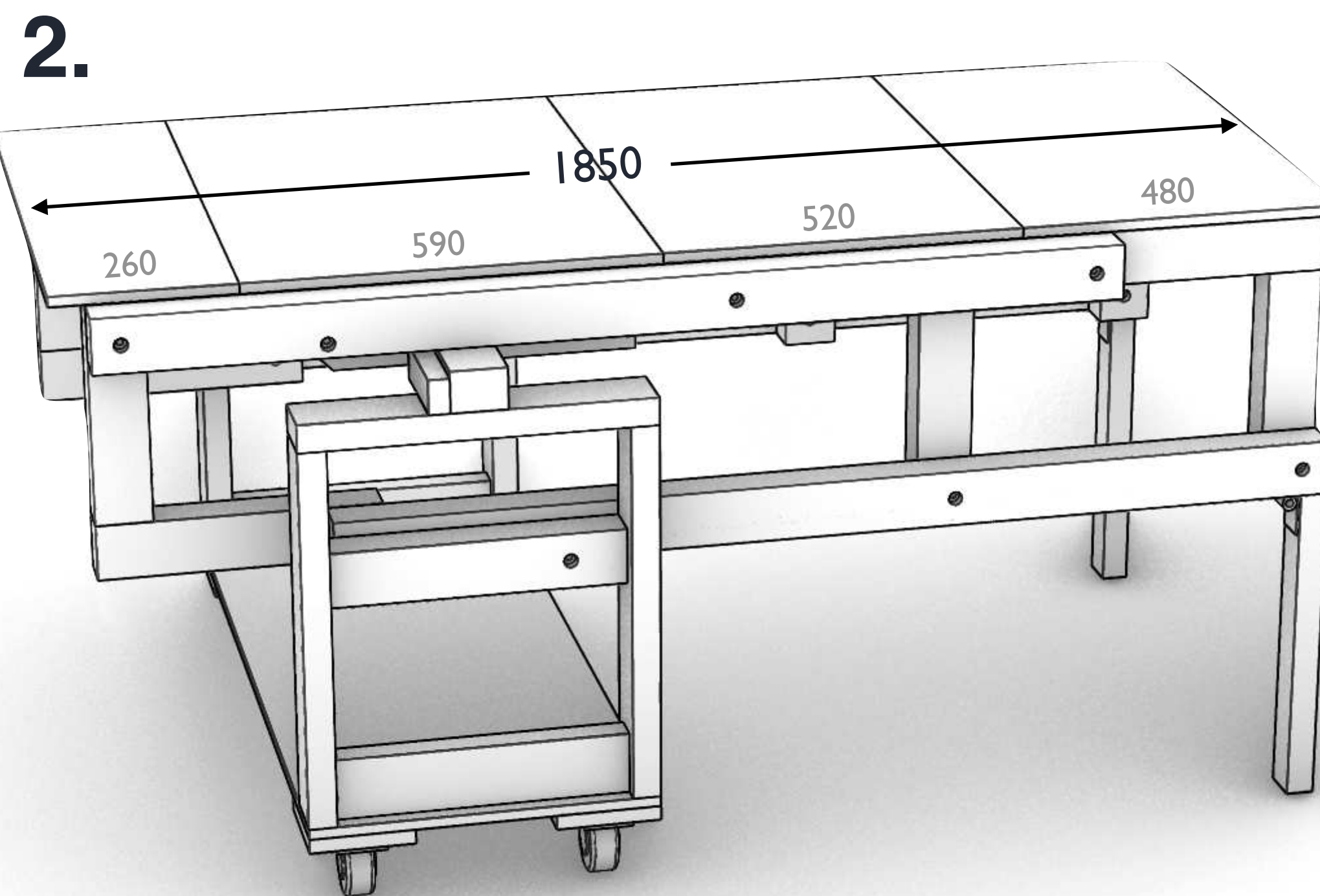

Ansicht nicht maßstabsgetreu